

(No Model.)

4 Sheets—Sheet 1.

K. RASMUSSEN.

CAR WHEEL AND AXLE LATHE.

No. 353,814.

Patented Dec. 7, 1886.

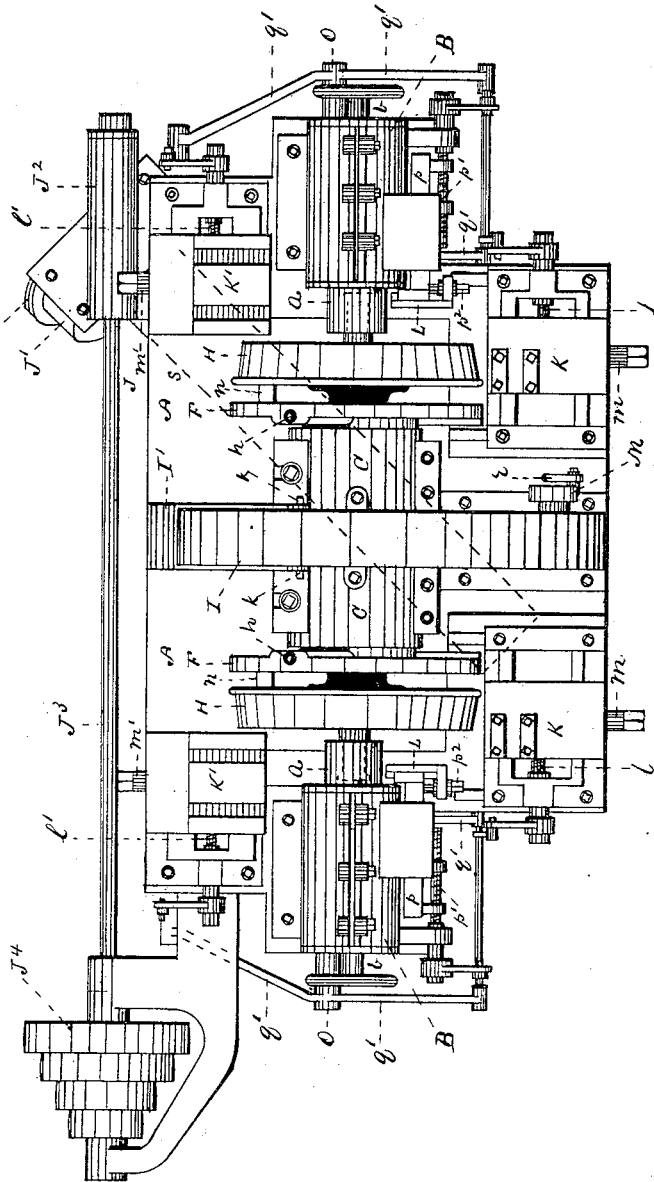

Fig. 1.

Witnesses.

H. M. Fowler
Charles Fowler

Inventor.

Knud Rasmussen
By Rufus Bennett Fowler
Atty.

(No Model.)

4 Sheets—Sheet 2.

K. RASMUSSEN.

CAR WHEEL AND AXLE LATHE.

No. 353,814.

Patented Dec. 7, 1886.

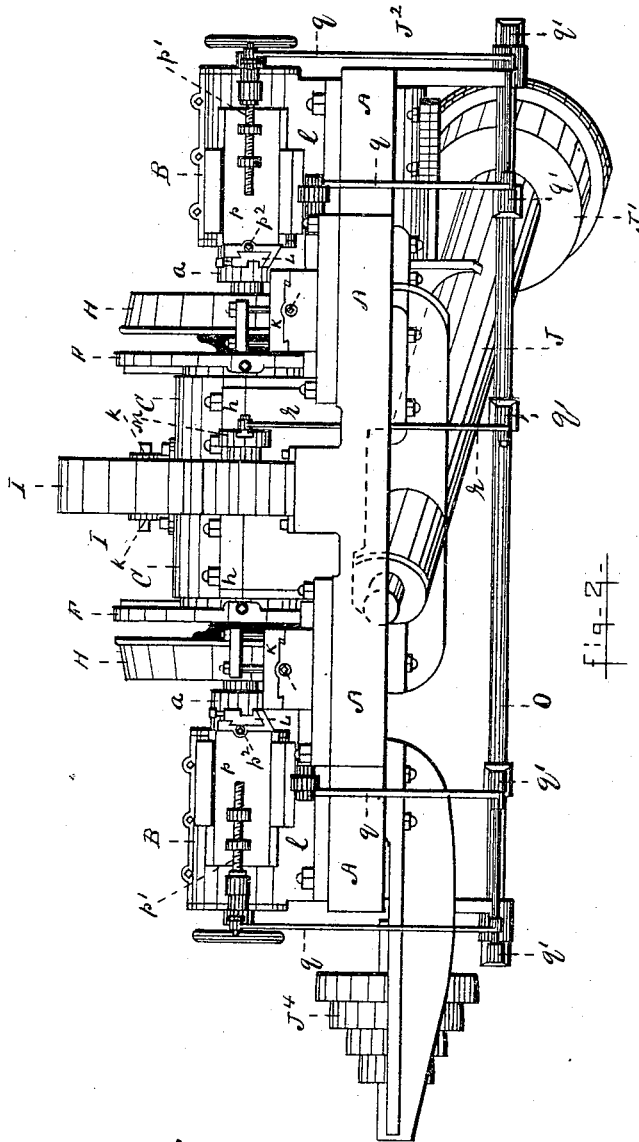

Witnesses.

H. M. Fowler
Charles Fowler

Inventor.

Knud Rasmussen
By Rufus Bennett Fowler
att'y.

(No Model.)

4 Sheets—Sheet 3.

K. RASMUSSEN.

CAR WHEEL AND AXLE LATHE.

No. 353,814.

Patented Dec. 7, 1886.

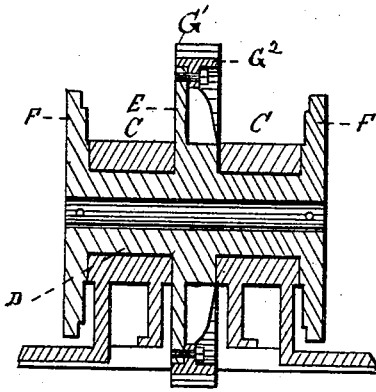

fig-4-

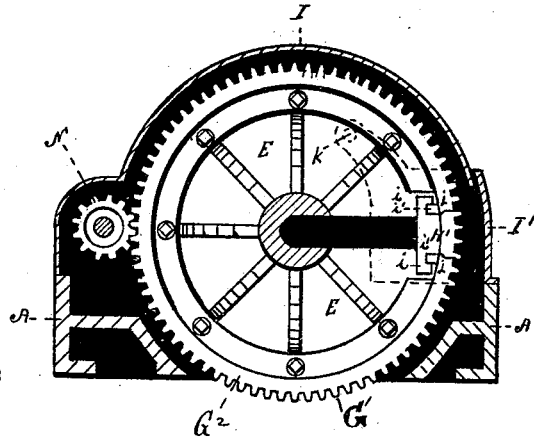

fig-3-

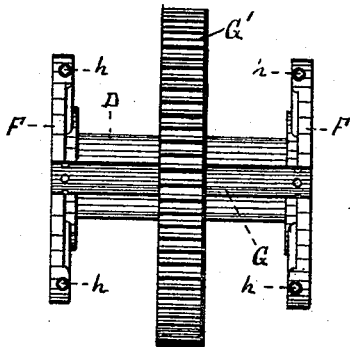

fig-5-

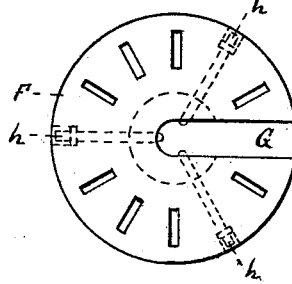

fig-6-

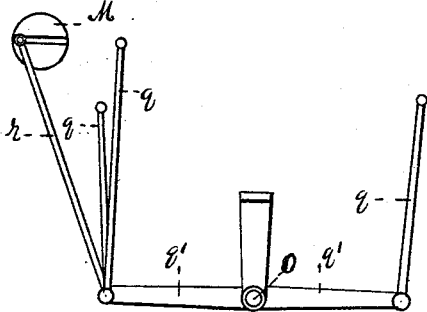

fig-2-

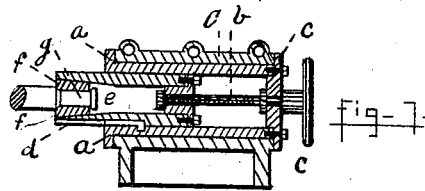

fig-7-

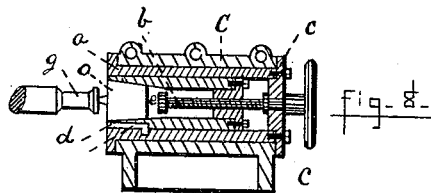

fig-8-

InWitnesses-

H. M. Fowler.
Charles Fowler

Inventor-

Knud Rasmussen
By Rufus Bennett Fowler
Atty.

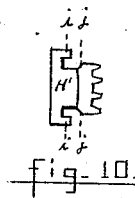

fig-10-

(No Model.)

4 Sheets—Sheet 4.

K. RASMUSSEN.

CAR WHEEL AND AXLE LATHE.

No. 353,814.

Patented Dec. 7, 1886.

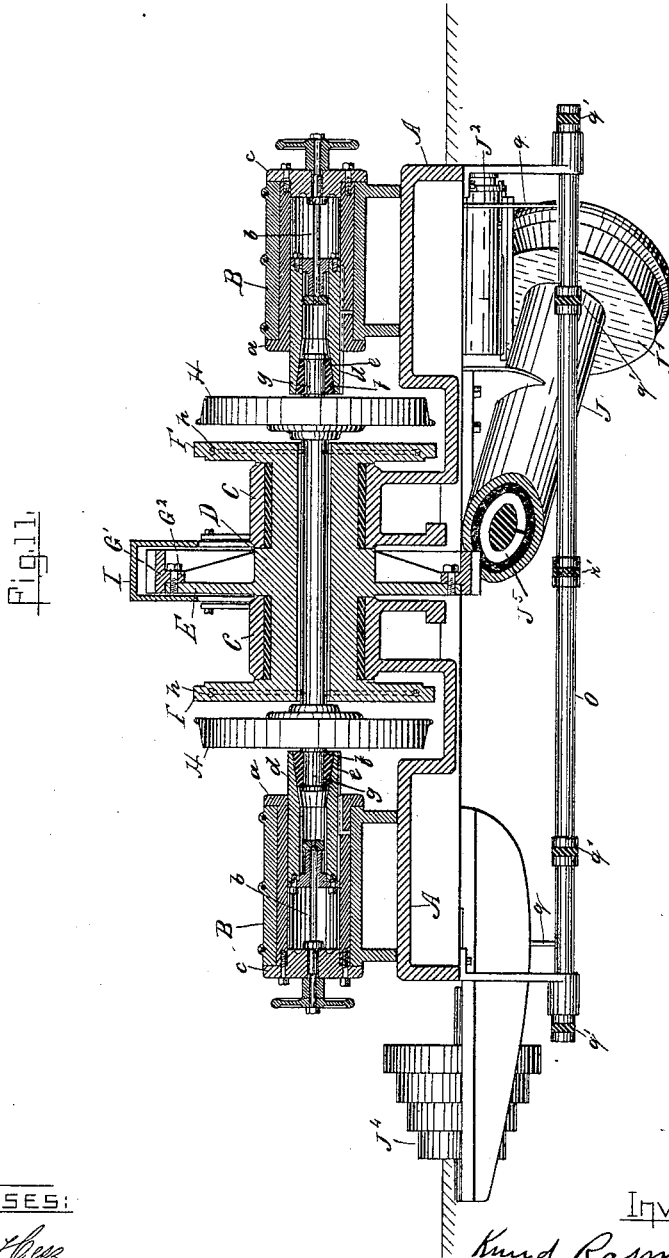

WITNESSES:
John Ross
N. C. Steer

INVENTOR
Knud Rasmussen
By *Rufus Bennett Fowler*
att.

UNITED STATES PATENT OFFICE.

KNUD RASMUSSEN, OF WORCESTER, MASSACHUSETTS, ASSIGNOR TO THE
POND MACHINE TOOL COMPANY, OF SAME PLACE.

CAR WHEEL AND AXLE LATHE.

SPECIFICATION forming part of Letters Patent No. 353,814, dated December 7, 1836.

Application filed April 17, 1885. Serial No. 162,603. (No model.)

To all whom it may concern:

Be it known that I, KNUD RASMUSSEN, a citizen of the United States, residing at Worcester, in the county of Worcester and State of Massachusetts, have invented a new and useful Improvement in Car Wheel and Axle Lathes, of which the following is a specification.

My invention relates to that class of car wheel and axle lathes which employ a central rotating spool having a gap or opening on one side to receive the car-axle; and it consists in the construction and arrangement of the several parts, as hereinafter set forth and described, reference being had to the accompanying drawings, in which—

Figure 1 represents a plan view of my improved lathe. Fig. 2 is a front elevation of the same. Fig. 3 is a transverse vertical sectional view of a portion of the lathe, showing the interior of the case inclosing the driving-wheel. Fig. 4 is a longitudinal sectional view of the rotating spool. Fig. 5 shows the spool removed from the lathe. Fig. 6 is one of the driving-plates. Fig. 7 is a vertical sectional view of one of the heads. Fig. 8 shows the same with a "center" inserted as used for turning the bearings of the axle. Fig. 9 is an end view of the rocking shaft and a portion of its connected feeding devices. Fig. 10 is a view of the detachable section of the gear G'. Fig. 11 is a longitudinal section.

Similar letters refer to similar parts in the several views.

A A denote the frame of the machine, which is intended to rest on the floor.

B B are head-stocks; C C, central bearings for the rotating spool D, which is shown in Fig. 5, and has a disk, E, attached to its center, and the driving-plates F F at the ends. A gap, G, extending radially through the spool D, disk E, and driving-plates F F, and a similar opening in the side of the central bearings, C C, (not shown in the drawings,) allow the car-axle to be placed concentrically with the spool D, bringing the car-wheels H H just outside the driving-plates F F. Sleeves a a are journaled in the head-stocks B B, having their axes coincident with the axis of the spool D. Screws b b, journaled in the heads c c, attached to the rotating sleeves a a, actuate

the internal sliding sleeves, d d, having tapering or conical chambers e e, in which blocks or brasses f f are placed, adapted to fit the conical chamber and the bearings g of the car-axle. When the bearings g have been inserted between the blocks f f, a sliding motion is given to the internal sleeves, d d, forcing their tapered surfaces over the blocks f f, thereby firmly chucking the bearing of the axle concentrically with the axis of the rotating spool D. Radial screws h h h are carried in each of the driving-plates F F, which are brought against the axle to check its vibration during the operation of turning.

The central driving-gear, G', is formed by fastening an annular toothed plate, G², to the disk E. The toothed plate G² has its interior diameter slightly larger than the diameter of the driving-plates F F, so it may be passed over them in the construction of the gear-wheel. The annular plate G² has also a gap corresponding with the gap in the disk E, which is closed by the toothed section H', having the hooked wings i i, fitting similar hooks, i' i', projecting inwardly from the plate G². Shoulders j j are formed on the sides of the section H'; or it may be made wedge shaped to prevent its being crowded inwardly. The hooked plate rests against the disk E, toward which it will be drawn by the action of the actuating screw, hereinafter described. The driving gear G' is inclosed in a shell or case, I, having an opening at its rear side to admit the axle, and closed by the curved cover I', hinged to the case at k.

In a shell, J, suspended beneath the frame A and placed obliquely to the axis of the gear G', I place a shaft journaled in suitable bearings in the shell and carrying a screw-thread or worm, J³, Fig. 11, engaging the teeth of the gear G', and having also at its lower end a gear-wheel inclosed in the shell or case J', which is driven by a screw-thread or worm inclosed in the shell J² and carried on the shaft J³, having the cone-pulley J⁴, to which power is applied.

The construction and action of the screw-threaded shafts, by which the rotary motion is conveyed from the cone-pulleys J⁴ to the gear G', are well known, they being common and familiar. Therefore I have not deemed it

necessary to show them in detail in the drawings, but have only indicated their respective positions by means of their inclosing shells or cases.

5 Sliding in ways upon the frame or bed A are the tool-rests K K and K' K', to which feeding motions are applied by means of the screws *ll'* and the hand-screws *mm'*, and which are adapted to properly present cutting-tools
10 to the tread and flange of the car-wheels H H, to which the rotary motion of the driving-plates F F is imparted by means of the dogs *nn*. When it is desired to turn the journals *gg* of the axle, the brasses *ff* are removed,
15 the sleeves *dd* are drawn into the sleeves *aa*, and centers *oo* inserted, for which purpose the tool-rests L L are provided, carried on plates *pp*, which slide in ways on the sides of the head-stocks B B, and are "fed" by the
20 screws *p'p'*, the cross-feed being effected by the hand-screws *p²p²*.

The feeding motions of all the cutting-tools—namely, those employed in turning the bearings *g* and those used for turning the treads
25 and flanges of the car-wheels themselves—are accomplished simultaneously by means of the crank-wheel M on a shaft journaled in the case J, and driven by the central driving-gear, G', through the pinion N, Fig. 3. The several
30 feeding-screws *ll' p'p'* have each a pawl-and-ratchet feeding device similar to that employed on planers, and too well known to require detailed illustration in the drawings or an extended description. These are connected
35 by rods *q* with arms *q'* on the rocking shaft O, to which an intermittent rocking motion is imparted by the crank-wheel M through the rod *r* and arm *r'* on the shaft O. By disconnecting the pawls from the ratchets in the
40 feeding devices the screws may be operated by hand, if desired, in the same manner as is now commonly done on planers.

Car wheel and axle lathes are now in use having a spool with a gap to allow the axle
45 to be inserted, and having a driving-gear in the center and driving-plates at the ends. Such I do not claim, broadly; neither do I claim the sliding sleeves having tapered chambers for the purpose of chucking the bearings
50 of the axle, for such have been heretofore used having gears attached thereto for the purpose of rotating the axle by means of the chucked axle-bearing.

By my present construction I secure a
55 steadiness of motion by means of the worm and gear which is not attainable when the spool is driven by a pinion or pinions engaging a gear thereon, and the action of a worm placed obliquely to the axis of the gear, as
60 shown by the broken lines *s*, Fig. 1, serves to draw the detachable toothed section H' of the annular gear against the disk E while it is engaged by the worm, and thereby hold it in place.

55 I not only drive the car-wheels by dogs near their periphery, as is done in some other ma-

chines of this class, but I also secure points of support for the axle at the section next the car-wheels by means of the radial screws carried in the driving-plates F F.

I do not confine myself to the arrangement of outer rotating sleeves, *aa*, journaled in the head-stocks and carrying inner sliding sleeves, with tapering chambers for chucking the bearings of the car-axles, or for receiving centers, as may be desired, as bearings may be provided in the head-stocks to receive the bearings of the axles; or the ordinary spindle carrying a center, as used in metal-turning lathes, may be employed; but the devices contained in the head-stocks B B are shown as those which may be advantageously used with the machine as herein described.

What I claim as my invention, and desire to secure by Letters Patent, is—

1. A lathe for turning car wheels and axles, consisting, essentially, of head-stocks carrying supports for the ends of the axle, a hollow spindle journaled in bearings coincident with the axle-supporting devices, said spindle having an opening permitting the axle to be received, and a worm-gear wheel attached thereto, and a worm adapted to engage said gear and rotate the hollow spindle, so as to impart longitudinal strain to the rotating spindle, and dogging devices by which the motion of the hollow spindle may be imparted to the axle, all combined and operating as set forth, and for the purpose specified.

2. In a lathe for turning car-wheels, the hollow rotating spindle having a gap to receive the car-axle, and having attached thereto the driving plates or disks F F, the central disk, E, and an annular toothed plate, G², attached to the central disk, E, said plate G² having its interior diameter larger than the disks F F, all combined as described, and for the purpose set forth.

3. In a car wheel and axle lathe, the combination, with a hollow driving-spindle having a gap permitting the car-axle to be received, of a central gear attached thereto having a corresponding cap, and a detachable toothed section of gear having hooked wings fitting corresponding hooks in the body of the gear, said hooked section resting against the web of the gear, toward which it is drawn by the action of the actuating-worm, and an actuating-worm engaging said central gear, and having its axis placed obliquely to the axis of the gear, substantially as described, and for the purpose set forth.

4. In a car wheel and axle lathe, the combination, with one or more sliding tool-rests, of a feeding mechanism adapted to actuate said tool-rests and present the cutting-tools to successive portions of the surfaces to be turned, said mechanism consisting of a rocking shaft journaled in bearings attached to the bed or frame of the machine, and having a series of arms extending radially therefrom, said arms being connected with a pawl-and-ratchet feed-

ing device on the feeding-screw of each of the
tool-rests, and a crank-wheel geared to the
revolving spindle of the lathe and connected
with a radial arm on said rocking-shaft,
5 whereby an intermittent motion is given to the
several feeding-screws, as and for the purpose
set forth.

In testimony whereof I have hereunto affixed
my hand this 13th day of April, 1885.

KNUD RASMUSSEN.

Witnesses:

RUFUS BENNETT FOWLER,
DAVID W. POND.